

Dell™ Latitude™ CPt V/CPt S Series  
and CPx H/CPx J Series

## SERVICE MANUAL

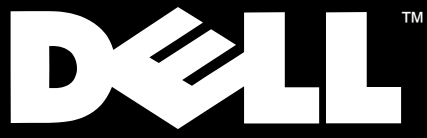



Dell™ Latitude™ CPt V/CPt S Series  
and CPx H/CPx J Series

**SERVICE MANUAL**

---

**Information in this document is subject to change without notice.  
© 2000 Dell Computer Corporation. All rights reserved.**

Reproduction in any manner whatsoever without the written permission of Dell Computer Corporation is strictly forbidden.

Trademarks used in this text: *Dell*, the *DELL* logo, and *Latitude* are trademarks of Dell Computer Corporation. Other trademarks and trade names may be used in this document to refer to either the entities claiming the marks and names or their products. Dell Computer Corporation disclaims any proprietary interest in trademarks and trade names other than its own.

February 2000 P/N 64PTN Rev. A00



# Contents

Recommended Tools . . . . .	2
Preparing to Work Inside Your Computer . . . . .	2
Before Working Inside Your Computer . . . . .	2
Screw Identification . . . . .	3
Disconnecting Interface Connectors . . . . .	5
Removing a Cable from a ZIF Interface Connector . . . . .	5
Replacing a Cable into a ZIF Interface Connector . . . . .	5
Field-Replaceable Parts and Assemblies . . . . .	6
Removing and Replacing Field-Replaceable Parts and Assemblies . . . . .	10
Hard-Disk Drive Assembly . . . . .	11
Removing the Hard-Disk Drive Assembly . . . . .	11
Replacing the Hard-Disk Drive Assembly . . . . .	11
Modular Bay Devices (Diskette Drive, CD-ROM Drive, DVD-ROM Drive, CD-RW Drive, SuperDisk LS-120 Drive, Battery, or Travel Module) . . . . .	12
Memory Module Cover . . . . .	12
Removing the Memory Module Cover . . . . .	12
Memory Modules . . . . .	13
Removing the Memory Modules . . . . .	13
Replacing the Memory Modules . . . . .	13
Keyboard Assembly . . . . .	14
Removing the Keyboard Assembly . . . . .	14
Replacing the Keyboard Assembly . . . . .	16
Microprocessor Module . . . . .	18
Removing the Microprocessor Module . . . . .	18
Replacing the Microprocessor Module . . . . .	19
Display Assembly . . . . .	20
Removing the Display Assembly . . . . .	20
14.1-Inch Display Assembly Bezel and LCD Panel . . . . .	21
Removing the 14.1-Inch Display Assembly Bezel . . . . .	21
Removing the 14.1-Inch LCD Panel . . . . .	22
Removing the 14.1-Inch LCD Flex Cable . . . . .	22
Replacing the 14.1-Inch LCD Flex Cable . . . . .	23
Replacing the 14.1-Inch LCD Panel . . . . .	24

12.1-Inch Display Assembly Bezel and LCD Panel . . . . .	25
Removing the 12.1-Inch Display Assembly Bezel . . . . .	25
Removing the 12.1-Inch LCD Panel Inverter . . . . .	26
Removing the 12.1-Inch LCD Flex Cable . . . . .	26
Replacing the 12.1-Inch LCD Flex Cable . . . . .	26
Replacing the 12.1-Inch LCD Panel Inverter . . . . .	27
Replacing the 12.1-Inch LCD Panel . . . . .	28
Display Assembly Latch. . . . .	29
Palmrest Assembly . . . . .	30
Removing the Palmrest Assembly . . . . .	30
Reserve Battery . . . . .	32
Removing the Reserve Battery . . . . .	32
Modem Assembly . . . . .	33
Removing the Modem Assembly . . . . .	33
Replacing the Modem Assembly. . . . .	33
System Board Assembly . . . . .	34
Removing the System Board. . . . .	34
Replacing the System Board . . . . .	35
Thermal Cooling Assembly . . . . .	36
Module Latch Assemblies . . . . .	37

## **Index**

### **Figures**

Figure 1.	Computer Orientation . . . . .	1
Figure 2.	Main Battery Removal. . . . .	3
Figure 3.	Screw Identification . . . . .	3
Figure 4.	Disconnecting a Cable from an Interface Connector . . . . .	5
Figure 5.	Exploded View-Computer. . . . .	10
Figure 6.	Hard-Disk Drive Assembly Removal . . . . .	11
Figure 7.	Modular Bay Device Removal. . . . .	12
Figure 8.	Memory Module Removal . . . . .	13
Figure 9.	Removing the Keyboard Assembly Screws . . . . .	14
Figure 10.	Keyboard Assembly Removal . . . . .	15
Figure 11.	Keyboard and Track Stick Cables and Connectors . . . . .	16
Figure 12.	Microprocessor Module Removal . . . . .	18
Figure 13.	Display Assembly . . . . .	20
Figure 14.	14.1-Inch Display Assembly Bezel . . . . .	21
Figure 15.	Display Assembly Bezel (bottom view). . . . .	23
Figure 16.	12.1-Inch Display Assembly . . . . .	25
Figure 17.	12.1-Inch LCD Flex Cable . . . . .	27
Figure 18.	12.1-Inch LCD Inverter . . . . .	28
Figure 19.	Removing the Palmrest Assembly Screws. . . . .	30

Figure 20.	Palmrest Assembly Removal . . . . .	31
Figure 21.	Modem Assembly . . . . .	33
Figure 22.	System Board Assembly . . . . .	35
Figure 23.	Thermal Cooling Assembly Removal . . . . .	36
Figure 24.	Module Latch Assemblies Removal . . . . .	37
Figure 25.	Left Module Latch and Spring . . . . .	38

**Tables**

Table 1.	Screw Placement Mat With Component Screw Counts and Sizes . . . . .	4
Table 2.	Parts and Assemblies . . . . .	6

## ***Read This First***

A prerequisite for using this manual to service Dell computer systems is a basic knowledge of PCs and prior training in PC troubleshooting techniques. In addition to information provided in this manual, Dell provides the *User's Guide* for troubleshooting procedures and instructions on using the Dell Diagnostics to test the computer system.

## ***Notes, Notices, and Cautions***

Throughout this guide, blocks of text may be accompanied by an icon and printed in bold type or in italic type. These blocks are notes, notices, and cautions, and they are used as follows:



*NOTE: A NOTE indicates important information that helps you make better use of your computer.*

**NOTICE: A NOTICE indicates either potential damage to hardware or loss of data and tells you how to avoid the problem.**



**CAUTION: A CAUTION indicates a potentially hazardous situation which, if not avoided, may result in minor or moderate injury.**



# **Dell™ Latitude™ CPt V/CPt S Series and CPx H/CPx J Series Service Manual**

This manual provides instructions for removing and replacing field-replaceable components, assemblies, and subassemblies in your Dell Latitude portable computer. Unless otherwise noted, each procedure in this manual assumes that a part can be replaced by performing the removal procedure in reverse order.

It is recommended that you use a book or something similar to support the display assembly when it is open nearly 180 degrees. The angle of the display assembly with respect to the bottom case should never be allowed to exceed 180 degrees. Also, when performing the procedures in this manual, the locations or directions relative to the computer are as shown in Figure 1 unless otherwise specified.

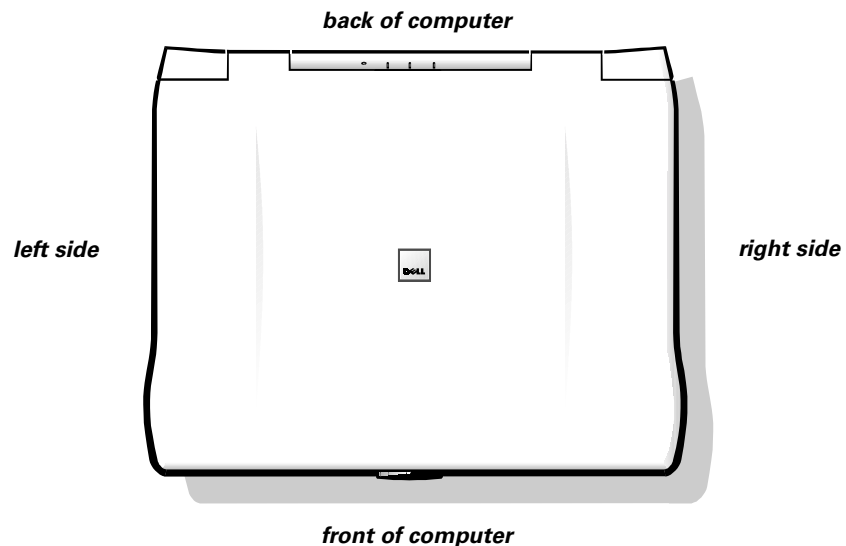

**Figure 1. Computer Orientation**

**NOTICE: Do not attempt to service the computer system yourself, except as explained in this manual and elsewhere in Dell documentation. Always follow installation and service instructions closely.**



## Recommended Tools

The procedures in this manual require the following tools:

- Number 1 magnetized Phillips-head screwdriver
- Small flat-blade screwdriver
- Small plastic scribe
- Microprocessor extractor

## Preparing to Work Inside Your Computer

**NOTICE:** Failure to perform the following steps could result in damage to the computer.

**NOTICE:** If working inside your computer involves the removal of the palmrest, note this information about the reserve battery. The reserve battery provides power to the computer's real-time clock (RTC) and nonvolatile random-access memory (NVRAM) when the computer is turned off. Removing the palmrest disconnects the reserve battery and causes the computer to lose the date and time information as well as all user-specified parameters in NVRAM. If possible, make a copy of this information before you disconnect the reserve battery.

**NOTICE:** Make sure that the work surface is clean to prevent scratching the computer cover.

### Before Working Inside Your Computer

1. Save any work in progress and close all open application programs.
2. Turn off the computer and any attached peripherals.



*NOTE: Make sure the computer is turned off and not in suspend-to-disk or hibernate mode. If you cannot shut down the computer using the computer's operating system, press and hold the power button for 4 seconds.*

3. If the computer is docked in a C/Dock Family Expansion Station or C/Port Family Advanced Port Replicator (APR), undock the computer.
4. Disconnect the computer and any attached peripherals from their electrical outlets to reduce the potential for personal injury or shock. Also disconnect any telephone or telecommunications lines from the computer.
5. Disconnect all other external cables from the computer.
6. Remove any installed PC Cards or plastic blanks from the PC Card slot.
7. Remove any installed devices in the modular device bay.

**NOTICE: To avoid damaging the system board, you must remove the main battery and secondary battery (if present) before you service the computer.**

8. Remove the main battery from the battery bay.

Slide the battery bay latch toward the right side of the computer. Then slide the battery out of the battery bay (see Figure 2).

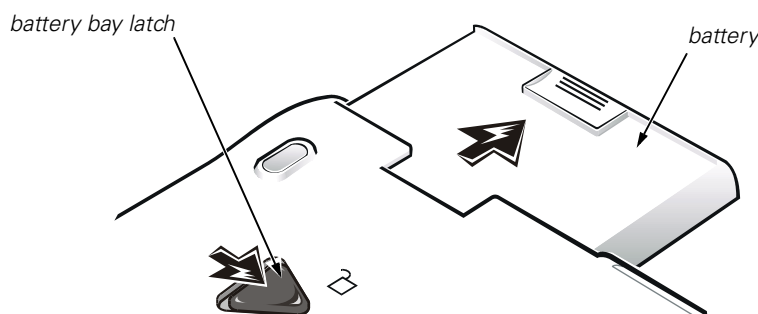

**Figure 2. Main Battery Removal**

9. Remove the secondary battery assembly (if present) from the modular bay.
10. Ground yourself by touching the unpainted metal surface of the I/O panel on the back of the computer.

While you work, periodically touch the I/O panel to dissipate any static electricity that might harm components.

## Screw Identification

The illustrations in the following removal procedures provide the correct screw length as part of the screw's label. A graphic for that length screw is also included in the illustration. Examples are shown in Figure 3. Match the actual screw to the graphic in the illustration to check for correct length.

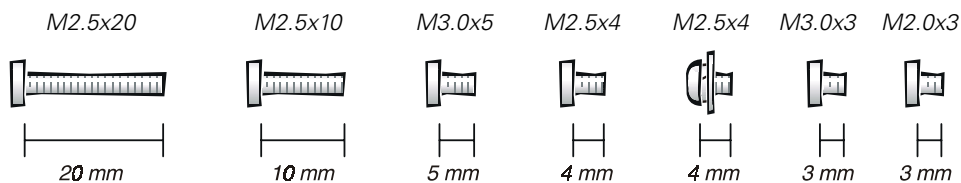

**Figure 3. Screw Identification**

**NOTICE: When reinstalling a screw, you must use a screw of the correct diameter and length. Otherwise, hardware damage could result. Make sure that the screw is properly aligned with its corresponding hole, and avoid overtightening.**

When you are removing and replacing components, photocopy the Table 1 placement mat as a tool to lay out and keep track of the component screws.

**Table 1. Screw Placement Mat With Component Screw Counts and Sizes**

<p><b>Hard-Disk Drive Assembly:</b> M3.0 x 5 (1 each)</p>	<p><b>Keyboard Assembly:</b> M2.5 x 10 (7 each)</p>	<p><b>Display Assembly:</b> M2.5 x 4 (3 each)</p>
<p><b>Display Assembly Bezel:</b> Rubber Screw Covers (4 each) Plastic Screw Covers (2 each)</p>	<p><b>Display Assembly Bezel:</b> M2.5 x 4 (6 each)</p>	<p><b>14.1-Inch Display Assembly LCD to Top Cover:</b> M2.0 x 3 (6 each)</p>
<p><b>12.1-Inch Display Assembly LCD to Top Cover:</b> M3.0 x 5 (4 each)</p>	<p><b>12.1-Inch Display Assembly Inverter:</b> M3.0 x 3 (3 each)</p>	<p><b>Palmrest Assembly:</b> M2.5 x 20 (5 each)</p>
<p><b>System Board Assembly:</b> M2.5 x 4 (2 each) (w/o modem assembly) M2.5 x 4 (1 each) M2.5 x 10 (1 each) (w/ modem assembly)</p>	<p><b>Microprocessor Shield Assembly:</b> <i>3 captive and 2 removable screws</i> M2.0 x 3 (2 each) M2.5 x 4 (1 each) (may not apply to your system)</p>	<p><b>Thermal Cooling Assembly and Exhaust Fan:</b> M2.5 x 4 (2 each)</p>

## Disconnecting Interface Connectors

Some of the computer's interface connectors are zero insertion force (ZIF) connectors. These connectors are not removable, but they must be released to disconnect the cable from them (see Figure 4).

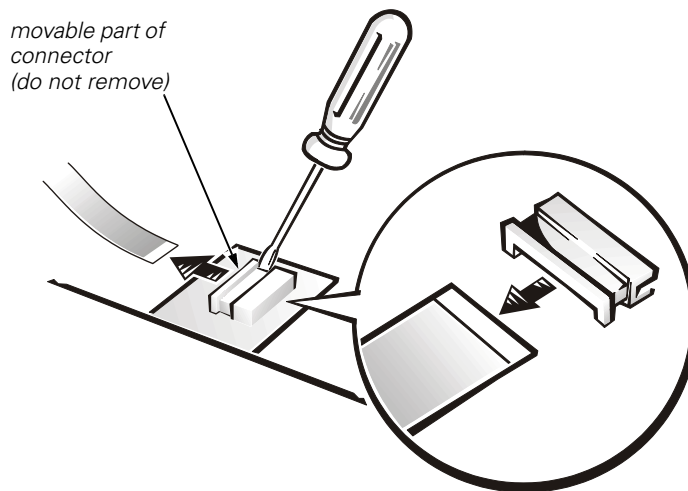

**Figure 4. Disconnecting a Cable from an Interface Connector**

**NOTICE: The ZIF interface connectors are fragile. To avoid damage, do not apply too much pressure to the movable part of the connector.**

### Removing a Cable from a ZIF Interface Connector

1. Insert a small flat-blade screwdriver behind the movable part of the connector.
2. Push gently sideways on the movable part of the connector until it releases the interface cable.
3. Grasp the interface cable and pull it out of the connector.

### Replacing a Cable into a ZIF Interface Connector

1. Use a small flat-blade screwdriver to open the movable part of the ZIF connector.
2. Orient the end of the interface cable with the ZIF connector, and insert the end of the cable into the connector.
3. While holding the cable in place, close the ZIF connector.

To ensure a firm connection, make sure the ZIF connector is completely closed.

## Field-Replaceable Parts and Assemblies

Table 2 lists the parts and assemblies available for the computer. Some parts may only be available as part of a service kit or assembly and are provided for reference only. The subsections that follow Table 2 provide instructions for removing and replacing these parts and assemblies.

**Table 2. Parts and Assemblies**

Part or Assembly Name	Order Name	Figure
<b>AC Adapter and Power Cords</b>		
Customer kit, AC adapter	CUS, ADPT, AC, EXT, 20V, 70W, NBK	
AC adapter	ADPT, AC, EXT, 20V, 70W, 3W, BA	
Power cable, U.S.	CORD, PWR, 110V, 6F, AC, 3W/3P, US	
<b>Battery (Main)</b>		
Customer kit, main battery	CUS, BTRY, 14.4V, 8CELL, LITH	2
	CUS, BTRY, 9.6V, 8CELL, NiMH (option for CPt S-Series only)	
Main battery	BTRY, 53WHR, 14.4V, 8CELL, LITH	
	BTRY, MAIN, 9.6V, 8, NiMH (option for CPt S-Series only)	
<b>Diskette Drive Subassembly</b>		
Diskette drive	CUS, SUBASSY, FD, F3, INT/EXT	7
<b>SuperDisk LS-120 Drive Subassembly</b>		
LS-120 drive subassembly	CUS, SUBASSY, VAS, LS120, 120MB, F3	7
<b>CD-ROM Drive Subassembly</b>		
CD-ROM drive	CUS, CD, 650M, I, 24X, zzz*	7
<b>CD-RW ROM Drive Subassembly</b>		
CD-RW ROM drive	CUS, CD-RW, 650M, I, zzz*	7
<b>DVD-ROM Drive Subassembly</b>		
DVD-ROM drive	SUBASSY, DVD, MPEGII, TSHBA	7
<b>Hard-Disk Drive Assembly</b>		
Hard-disk drive, subassembly	HD, xxxxGB, yyMM, zzz*	6
Hard-disk drive	MOD, HD, xxxxGB, I, F2, yyMM, zzz* CUS, HD xxxxGB, I, yyMM, zzz*	
Hard-disk drive interface board	PWA, INTERCON, HD	

\* Substitute the drive capacity for xxxxGB, the drive height for yyMM, and zzz for the manufacturer's name.

**Table 2. Parts and Assemblies** (continued)

<b>Part or Assembly Name</b>	<b>Order Name</b>	<b>Figure</b>
<b>Hard-Disk Drive Carrier Assembly</b>		
Hard-disk drive carrier	ASSY, CARR, HD	
<b>Palmrest Assembly</b>		
Palmrest assembly	ASSY, PLMRST, TPAD	20
Palmrest screws (5)	SCR, M2.5X20, PHH, LP, ZPS	19
<b>Battery (Reserve)</b>		
Reserve battery	CUS, BTRY, RESERVE	
<b>Keyboards (Dual Pointing)</b>		
Euro-language specific keyboard	KYBD, <i>nn</i> , <i>iiii</i> *, D-PTG, EMEA	10
Asian-language specific keyboard	KYBD, <i>nn</i> , <i>iiii</i> *, D-PTG, APCC	
English (U.K.)	KYBD, 88, UK, D-PTG, EMEA	
English (U.S.)	KYBD, 87, US, D-PTG, US	
English (International)	KYBD, 87, US, INT, D-PTG, EMEA	
Keyboard screws (7)	SCR, M2.5X10, PHH, LP, ZPS	9
* Substitute the number of keys for " <i>nn</i> " and the specific language for " <i>iiii</i> ."		
<b>LCD Assembly, 14.1-Inch Display Panel</b>		
14.1-inch LCD display	LCD, TFT, 14.1, <i>zzz</i> *	14
<b>LCD Assembly, 12.1-Inch Display Panel</b>		
12.1-inch LCD display	LCD, TFT, 12.1, <i>zzz</i> *	16
<b>12.1-Inch Display Panel Inverter</b>		
12.1-inch LCD display panel inverter	INVRTR, LCD, 12.1, <i>zzz</i> *	16, 18
<b>Display Top Cover Assembly</b>		
14.1-inch display top cover	ASSY, CVR, TOP, LCD, TFT, 14.1	14
14.1-inch display bezel	ASSY, BZL, LCD, TFT, 14.1	14
12.1-inch display top cover	ASSY, CVR, TOP, LCD, 12.1	16
12.1-inch display bezel	ASSY, BZL, LCD, 12.1	16
Display assembly screws	SCR, M2.5x4, PHH, LP, ZPS	
14.1-inch flex cable	ASSY, CBL, FLX, TFT	14
12.1-inch flex cable	ASSY, CBL, FLX, W/EXTN, 12.1	16, 17

**Table 2. Parts and Assemblies** (continued)

<b>Part or Assembly Name</b>	<b>Order Name</b>	<b>Figure</b>
14.1 display, right hinge	HNG, RT, LCD, 14.1	
14.1 display, left hinge	HNG, LF, LCD, 14.1	
12.1 display, right hinge	HNG, RT, LCD, 12.1	
12.1 display, left hinge	HNG, LF, LCD, 12.1	
14.1-inch LCD panel screw	SCR, M2X3, PHH, LP, ZPS	
12.1-inch LCD panel screw	SCR, M3X5, PHH, LP, ZPS	
12.1-inch LCD inverter	SCR, M3X3, PHH, LP, ZPS	16, 18
LCD hinge screw	SCR, M2.5X4, PHH, LP, ZPS	
LCD bezel screw	SCR, M2.5X4, PHH, LP, ZPS	
<b>LCD Latch Assembly</b>		
Display latch assembly	ASSY, LATCH, SPR, DIS	14, 16
<b>Bottom Case Assembly</b>		
Bottom assembly	ASSY, CVR, BTM, BASE, PLSTC, CH-ST	22
<b>Modem Subassembly</b>		
Internal Modem (installed)	MOD, MDM, INT, NBK, CH-ST	21
Modem Cable Kit	KIT, CBL, PHONE, 4PRJ11, MOM	
Internal Modem	MDM, INT, NBK, CHRLST	
Modem Screw	SCR, M2, 5X15, KSH, MS, BCS, W/ WSHR	
Internal Modem (not installed)	MOD, NO, MDM, INT, NBK, CH-ST	
Modem Screw	SCR, M2, 5X4, RND, MS, NPL, W/ WSHR	
Case Plug	PLUG, PLSTC, MDM, CH-ST	
<b>Memory Modules</b>		
Customer kit, memory module, 32-MB	CUS, 32MB, DIMM, SDRAM	8
Customer kit, memory module, 64-MB	CUS, 64MB, DIMM, SDRAM	
Customer kit, memory module, 128-MB	CUS, 128MB, DIMM, SDRAM	
Customer kit, memory module, 192-MB	CUS, 192MB, DIMM, SDRAM	
Customer kit, memory module, 256-MB	CUS, 256MB, DIMM, SDRAM	

**Table 2. Parts and Assemblies** (continued)

<b>Part or Assembly Name</b>	<b>Order Name</b>	<b>Figure</b>
<b>Memory Door</b>		
Memory door assembly	DOOR, MEM, MET, NB	
<b>System Board Assembly</b>		
System board assembly, service kit	SVCKIT, MB ASSY, PWA, ENGINE	22
Service tag installation diskette	DSK, BIOS, FLDSVC, F3, US	
BIOS flash diskette	KIT, BIOS, FLASH, UPG, F3	
Diagnostic diskette	KIT, DSK, DIAG, F3, WW	
System board assembly	ASSY, PWA, ENGINE	
Main system board	PWA, PLN, 0M, NB	
Exhaust fan and cable	FAN, 25X25X10	
Thermal cooling assembly	SVC, SUBASSY, HTSNK, CPU, HYB	
<b>Microprocessor</b>		
Microprocessor, Service Kit	SVC, PRM, PCA	12
Microprocessor shield/thermal cooling assembly arm screw	SCR, M2X3, PHH, LP, ZPS	12
Thermal cooling assembly	SCR, M2.5X4, PHH, LP, ZPS	23
System board assembly	SCR, M2.5X4, PHH, LP, ZPS	22
<b>Microprocessor Shield</b>		
Microprocessor shield	ASSY, SHLD, EMI, PRC, MET	12
<b>Miscellaneous Hardware</b>		
Service Kit, latch, slider, Button	LTCH, BTN, Module	
Foot, Rubber, Black (4 each)	Foot, Rbr, Blk	
Foot, Rubber, Strike Zone, Black	Foot, Rbr, Strike Zone, Blk	



# Removing and Replacing Field-Replaceable Parts and Assemblies

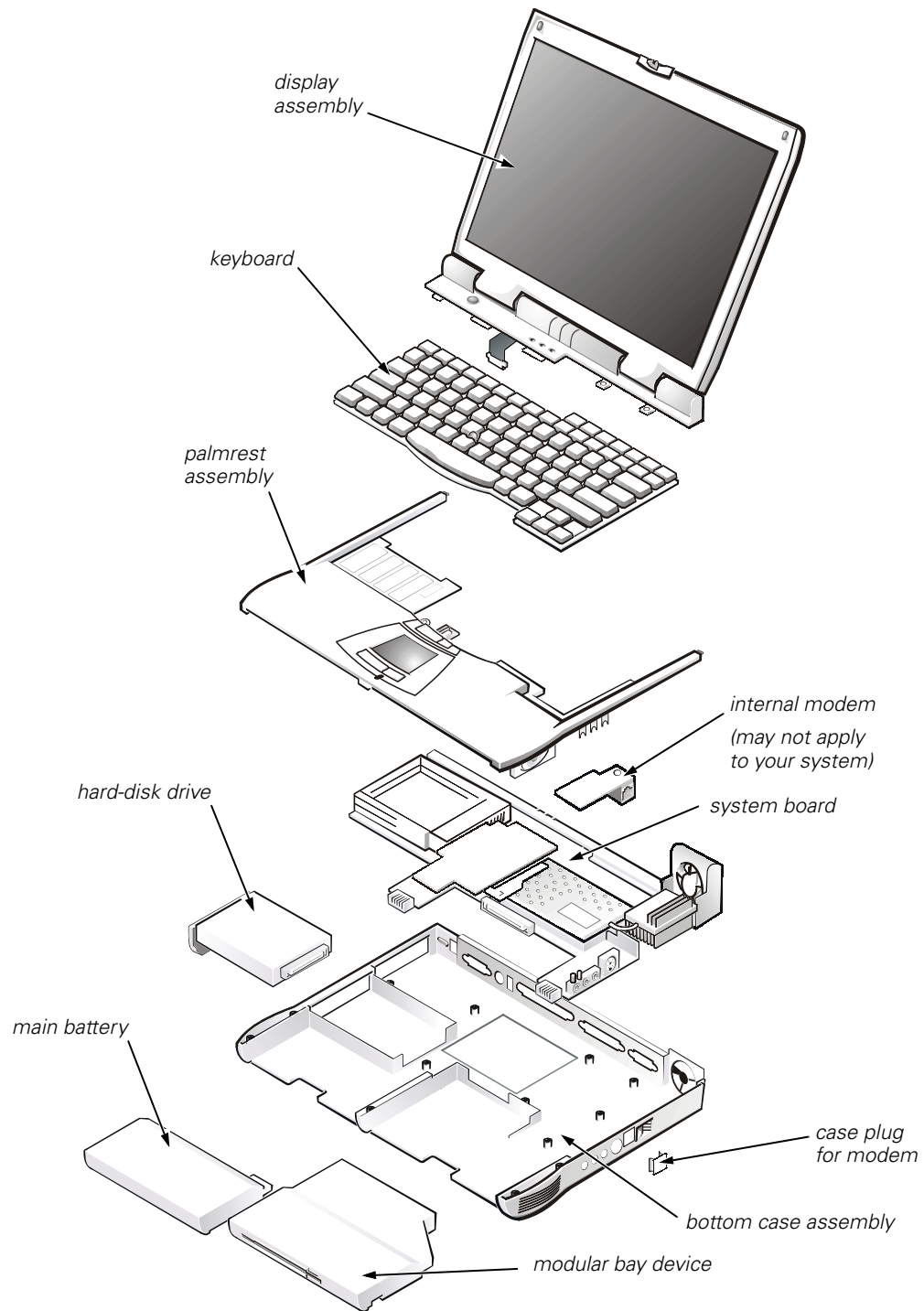

**Figure 5. Exploded View—Computer**

The following subsections provide instructions for removing and replacing field-replaceable parts and assemblies.

## Hard-Disk Drive Assembly

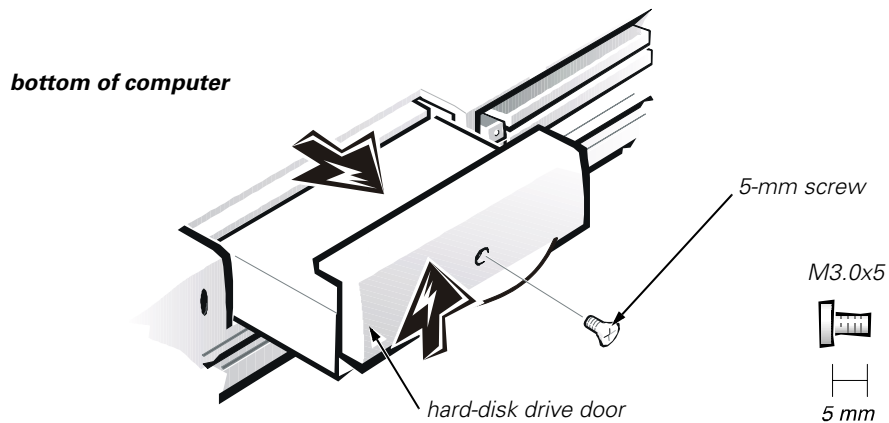

**Figure 6. Hard-Disk Drive Assembly Removal**

**NOTICE:** To avoid damaging the system board, you must remove the main battery before you service the computer.

**NOTICE:** Make sure that the work surface is clean to prevent scratching the computer cover.

**NOTICE:** The hard-disk drive is very sensitive to shock. Handle the assembly by its edges (do not squeeze the top of the hard-disk drive case), and avoid dropping it.

### Removing the Hard-Disk Drive Assembly

1. Remove the main battery and secondary battery (if present).
2. Turn the computer over, and remove the 5-mm screw from the center of the hard-disk drive door (see Figure 6).

The drive is on the left side of the computer.

3. Slide the drive door up and pull the drive assembly out of the computer.

### Replacing the Hard-Disk Drive Assembly

1. Push the drive assembly into the opening on the left side of the computer.
2. Slide the drive door down until it aligns with the cover.
3. Turn the computer over and replace the 5-mm screw on the drive door.

## **Modular Bay Devices (Diskette Drive, CD-ROM Drive, DVD-ROM Drive, CD-RW Drive, SuperDisk LS-120 Drive, Battery, or Travel Module)**

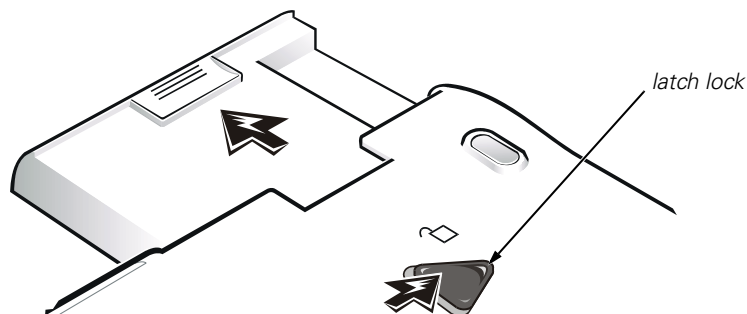

**Figure 7. Modular Bay Device Removal**

**NOTICE: Make sure that the work surface is clean to prevent scratching the computer cover.**

1. Close the display, and turn the computer upside down on a flat work surface.
2. Push the module latch toward the unlock icon. Keep holding the latch open while pulling the device out of the modular bay with the other hand (see Figure 7).

## **Memory Module Cover**

**NOTICE: To avoid damaging the system board, you must remove the main battery before you service the computer.**

**NOTICE: Make sure that the work surface is clean to prevent scratching the computer cover.**

### *Removing the Memory Module Cover*

1. Remove the main battery and secondary battery (if present).
2. Close the display, and turn the computer upside down on a flat work surface.
3. Release the memory module cover.

Insert a flat-blade screwdriver under the indentation in the bottom case assembly and lift the cover.

## Memory Modules

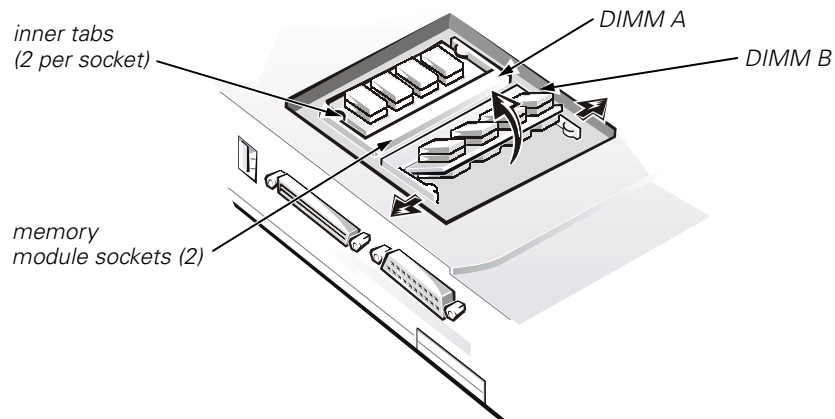

**Figure 8. Memory Module Removal**

### Removing the Memory Modules

**NOTICE: To avoid damaging the system board, you must remove the main battery before you service the computer.**

1. Remove the main battery and secondary battery (if present).
2. Remove the memory module cover.

**NOTICE: To avoid possible damage to the memory module from electrostatic discharge (ESD), ground yourself by touching the unpainted metal surface of an I/O connector on the computer's back panel.**

3. To release a memory module from its socket, carefully spread apart the inner tabs of the memory module socket just far enough for the memory module to disengage from the socket. The module should pop up slightly (see Figure 8).
4. Lift the memory module out of its socket.

### Replacing the Memory Modules

1. If you only have one memory module, install it in the DIMM A socket.



*NOTES: 192-MB memory modules are designed for either the socket labeled DIMM A or the socket labeled DIMM B; they are not interchangeable. Be sure that the memory module is inserted with the double-stacked memory chips facing you. A 192-MB memory module inserted with the double-stacked memory chips facing down does not fit properly in the socket.*

*Memory modules are keyed, or designed to fit into their sockets, in only one direction. The slots on the system board are notched so that the memory module can be firmly seated only one way.*

2. Align the memory module's edge connector with the slot in the center of the memory module socket. With the module at a 45-degree angle, press the memory module's edge connector firmly into the memory module socket.
3. Pivot the memory module down until it clicks into place. If you do not hear a click as each end of the memory module snaps into the tabs, remove the memory module and reinstall it.
4. Replace the memory module cover.

## Keyboard Assembly

**NOTICE:** To avoid damaging the system board, you must remove the main battery before you service the computer.

**NOTICE:** Make sure that the work surface is clean to prevent scratching the computer cover.

### Removing the Keyboard Assembly

1. Remove the main battery and secondary battery (if present).
2. Close the display assembly, and turn the computer upside down on a flat work surface.

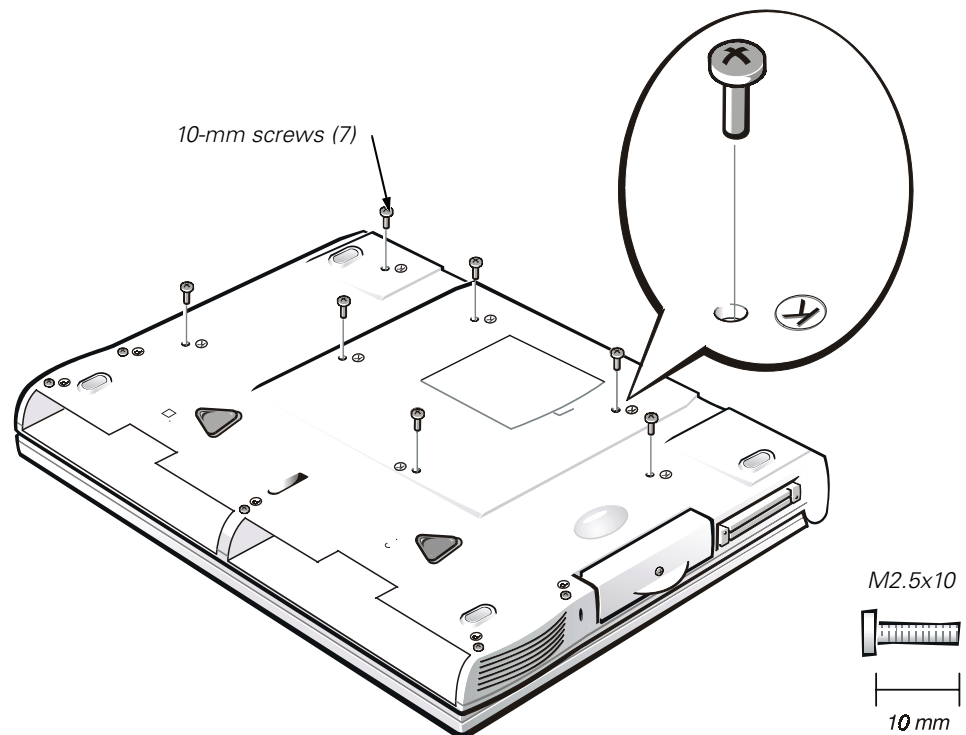
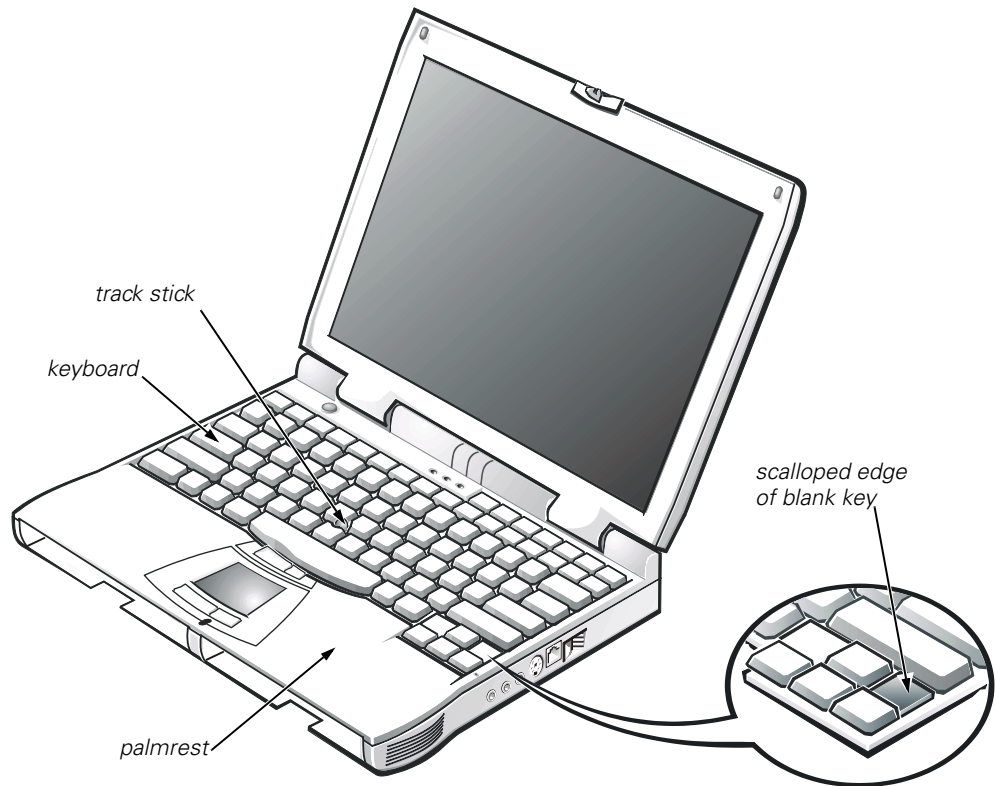

**Figure 9. Removing the Keyboard Assembly Screws**

3. Remove the seven 10-mm screws, labeled with a "circle K," that secure the keyboard to the computer (see Figure 9).
4. Turn the computer right-side up and open the display.

**NOTICE: The keycaps on the keyboard are fragile, easily dislodged, and time-consuming to replace. Be careful when removing and handling the keyboard.**

5. Release the keyboard from the palmrest assembly by inserting a small flat-blade screwdriver under the edge of the blank key (see Figure 10), and lift the right edge of the keyboard.



**Figure 10. Keyboard Assembly Removal**

6. Lift the keyboard out of the palmrest.
7. Rotate the keyboard over the left edge of the computer (see Figure 11).
8. Rest the key face of the keyboard on the left side of the computer.

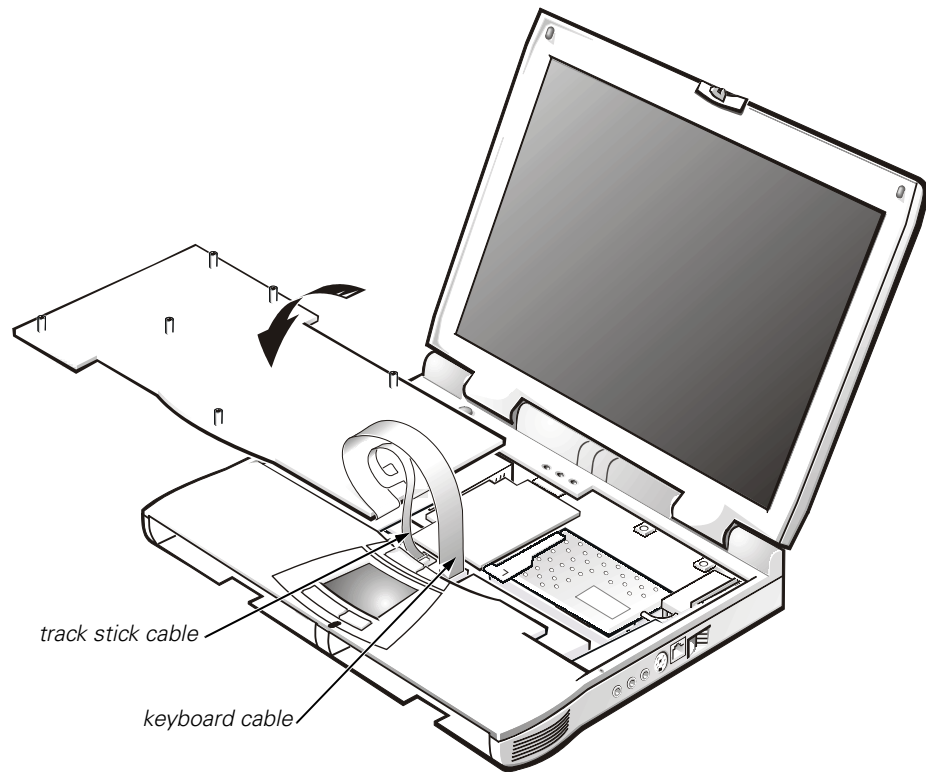

**Figure 11. Keyboard and Track Stick Cables and Connectors**

9. Disconnect the keyboard cable from the connector on the system board.  
The keyboard cable is the wide, flexible cable.
10. Carefully disconnect the track stick cable from the ZIF connector on the palmrest's flexible printed circuit board.
11. Remove the keyboard assembly.

### **Replacing the Keyboard Assembly**

1. Place the keyboard on the left side of the computer with the keys face down (see Figure 11).

2. Connect the track stick cable to the ZIF connector.

Ensure that the contact side of this cable is face down when you insert the cable into the track stick ZIF interface connector.

3. Connect the keyboard cable to the connector on the system board.

Ensure that the contact side of this cable is face down when you insert the cable into the keyboard ZIF interface connector.

**NOTICE: Position the track stick and keyboard cables so they are not twisted when you reconnect them to the system board.**

4. Carefully turn the keyboard over and fit the keyboard into place.

Ensure that the track stick and keyboard cables are not twisted as you lower the keyboard into the palmrest.

5. To push the keyboard down, press on the blank key located below the right <Shift> key.
6. Check that the keyboard is correctly installed. The keys should be flush with the left and right surfaces of the palmrest.
7. Carefully turn the computer over and reinstall the seven 10-mm screws.

Start by installing the outermost screws on the left and right sides of the computer and then work inward to the center.



## Microprocessor Module

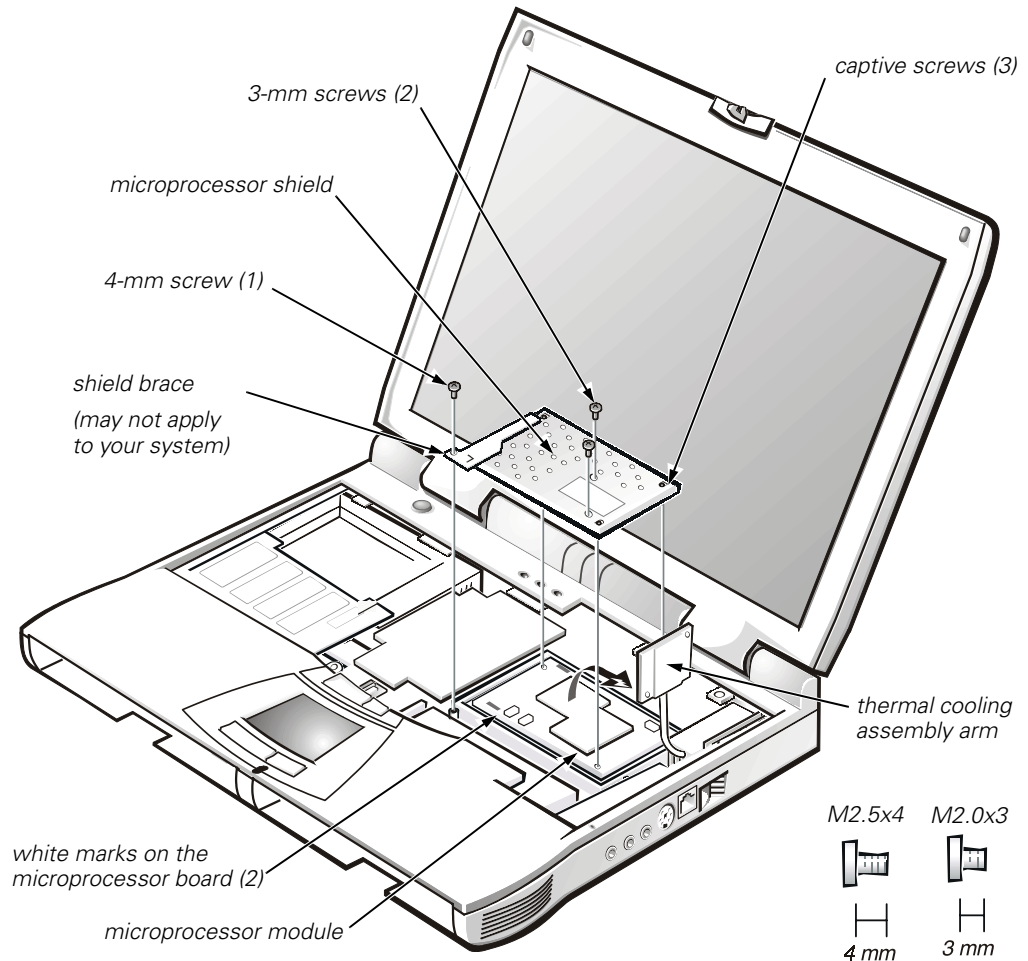

**Figure 12. Microprocessor Module Removal**

### Removing the Microprocessor Module

**NOTICE: To avoid damaging the system board, you must remove the main battery before you service the computer.**

1. Remove the main battery and secondary battery (if present).
2. Remove the keyboard assembly.

**NOTICE: To ensure maximum cooling for the microprocessor, do not touch the heat transfer areas on the thermal cooling assembly. The oils in your skin reduce the heat transfer capability of the thermal pads.**

3. Remove the two 3-mm screws on the microprocessor shield securing the thermal cooling assembly to the microprocessor module (see Figure 12).
4. Loosen the three captive screws securing the microprocessor shield to the microprocessor module.



*NOTE: The microprocessor shield brace may not be present on your system, if the brace is not present continue with step 6.*

5. Remove the 4-mm screw that secures the microprocessor shield brace (see Figure 12).
6. Remove the microprocessor shield.
7. Rotate the arm of the thermal cooling assembly up and away from the microprocessor module.

**NOTICE: When removing the microprocessor module, pull the module straight up. Do not move the tool from side to side to extract the processor board.**

8. Use a microprocessor extractor tool to remove the microprocessor module.

The tool fits on the left side of the module aligned with white marks on the front and back edge of the processor board (see Figure 12).

### *Replacing the Microprocessor Module*

**NOTICE: Proper seating of the microprocessor module requires a considerable amount of force (approximately 35 pounds [16 kilograms]) applied above the module connector.**

**NOTICE: A microprocessor module that is not properly seated can result in an intermittent connection and subsequent failures.**

1. Align the microprocessor connector on the left side of the board and press down firmly on the metal plate that is directly over the connector.

When the microprocessor module is fully seated, all four corners are aligned to the same height. If one or more corners of the module are higher than the others, the module is not seated correctly.

2. To ensure the microprocessor module is fully seated, apply pressure over the corner without the mounting screw hole.



*NOTE: If your system uses a microprocessor shield with the brace as shown in Figure 12, the 4-mm screw used in step 6 secures this corner.*

3. Rotate the arm of the thermal cooling assembly into place.
4. Replace the microprocessor shield.
5. Replace the two 3-mm screws that secure the thermal cooling assembly arm and shield to the microprocessor module.
6. Replace the 4-mm screw securing the shield brace (if present).
7. Tighten the three captive screws on the corners of the shield to secure the microprocessor module and shield (see Figure 12).

## Display Assembly

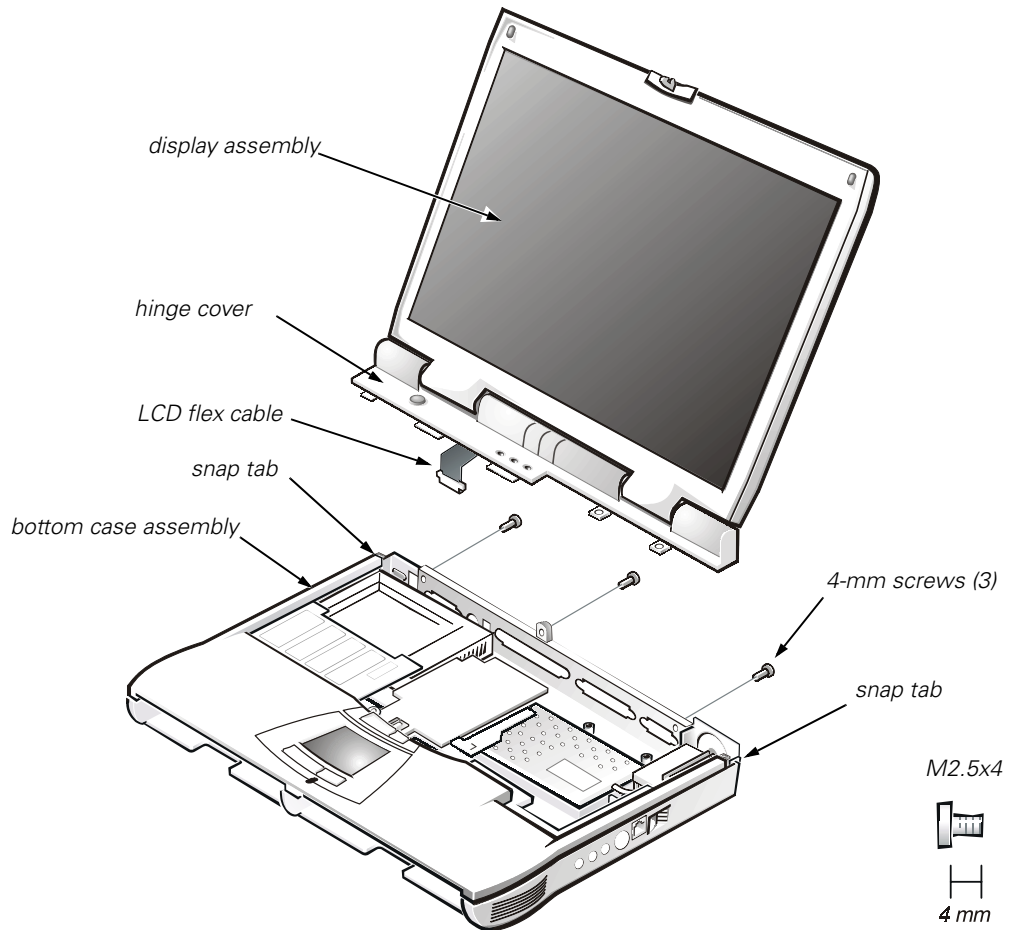

**Figure 13. Display Assembly**

### Removing the Display Assembly

**NOTICE:** To avoid damaging the system board, you must remove the main battery before you service the computer.

**NOTICE:** Do not remove the palmrest before you remove the display.

1. Remove the main battery and secondary battery (if present).
2. Remove the keyboard.
3. Close the display and remove the three 4-mm screws, labeled with a "circle D," from the back of the computer (see Figure 13).
4. Open the display and disconnect the LCD flex cable from the connector on the system board by pulling the connector straight up.
5. Lift the display assembly from the bottom case assembly. Pry the hinge cover loose at the seam from the snap tabs on the bottom assembly (see Figure 13).



**NOTE:** Always remove and replace the LCD panel as a complete assembly.

## 14.1-Inch Display Assembly Bezel and LCD Panel

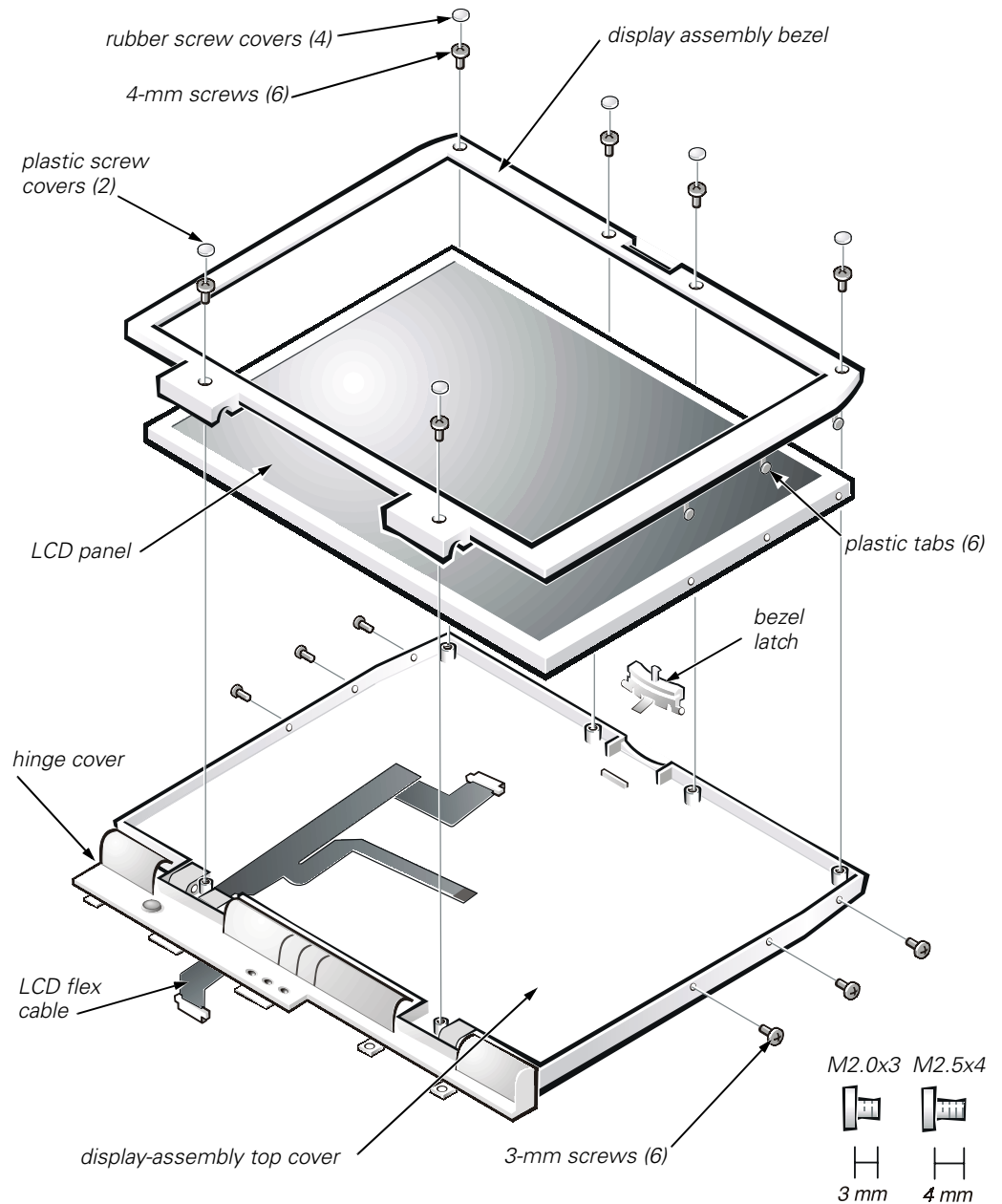

**Figure 14. 14.1-Inch Display Assembly Bezel**

### Removing the 14.1-Inch Display Assembly Bezel

1. Use a scribe to carefully pry the four rubber screw covers out of the four screw holes located at the top of the bezel on the front of the display assembly.
2. Remove the four 4-mm screws located at the top of the bezel on the front of the display assembly (see Figure 14).

3. Use a scribe to carefully pry the two plastic screw covers out of the two screw holes located at the bottom of the bezel on the front of the display assembly.
4. Remove the two 4-mm screws from the bottom of the bezel.

**NOTICE: The bezel tabs are fragile. Handle the bezel carefully to avoid breaking the plastic tabs off.**

5. Separate the bezel from the display-assembly top cover.

The bezel is secured by three plastic tabs on the left and three plastic tabs on the right side of the display-assembly top cover (see Figure 14).

### *Removing the 14.1-Inch LCD Panel*

1. Remove the display assembly bezel.
2. Remove the three 3-mm screws on the left side of the LCD panel and the three 3-mm screws on the right side of the LCD panel (see Figure 14).
3. Lift and rotate the top of the LCD panel out of the top cover. Disconnect the ZIF interface connector and the display-assembly interface cable connector.
4. Lift the LCD panel out of the top cover.

### *Removing the 14.1-Inch LCD Flex Cable*

**NOTICE: Make sure that the work surface is clean to prevent scratching the computer cover.**

1. Remove the LCD panel.
2. Turn the display assembly upside down on a flat work surface.
3. Remove the 4-mm screw securing the metal cable clip to the left hinge of the display-assembly top cover.
4. Remove the flex cable out from under the plastic strain relief retainer located on the bottom of the display-assembly hinge cover.
5. Remove the flex-cable retaining clip from the bottom of the hinge cover located at the bottom of the display-assembly hinge cover.
6. Pry the hinge-cover assembly apart slightly from the display assembly, allowing just enough space for the flex cable to pass through the opening.
7. Slide the cable through the opening.

## Replacing the 14.1-Inch LCD Flex Cable

1. Find the manufacturer's name, either *Samsung* or *IBM/Hitachi*, on the back of the replacement LCD panel.
2. *If your replacement LCD panel is a Samsung* — Install the display bezel clip (if one is not present) by placing the bezel slot over the hinge tab and pressing gently until it snaps (see Figure 15).

*If your replacement LCD panel is an IBM/Hitachi* — Remove the display bezel clip (if present) by gently prying it up with a small-blade screwdriver (see Figure 15).

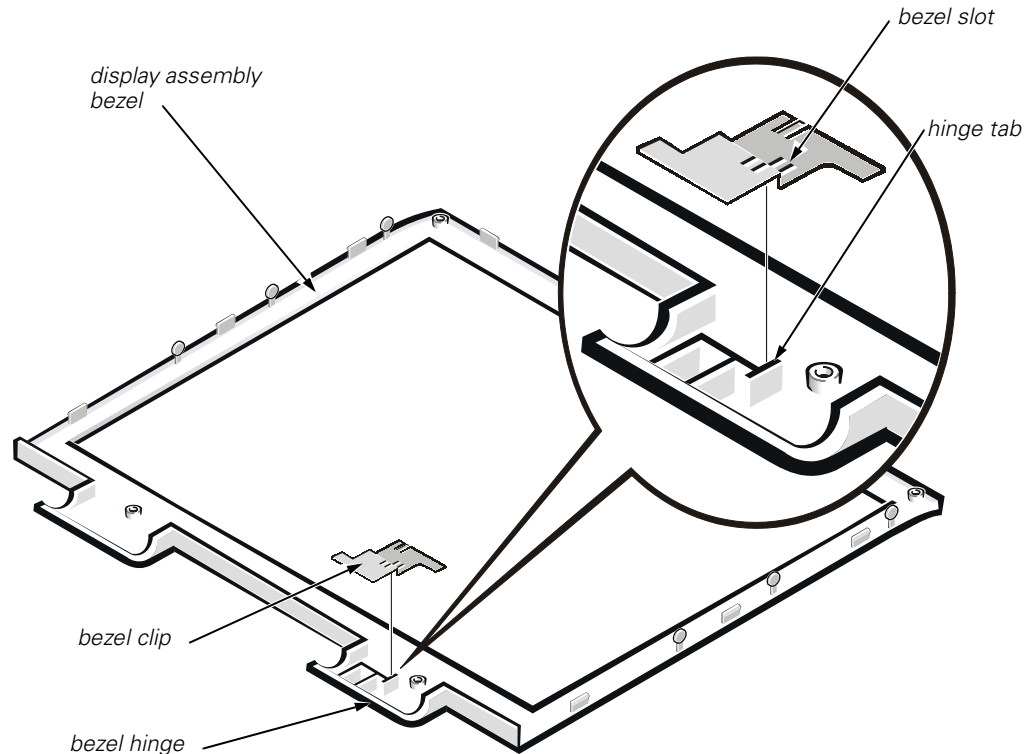

**Figure 15. Display Assembly Bezel (bottom view)**

3. Install the new flex cable that accompanied the replacement LCD display.
4. Pry the hinge-cover assembly apart from the display assembly, allowing just enough space for the flex cable to pass through the opening.
5. Slide the cable through the opening.
6. Attach the flex-cable retaining clip to the bottom of the hinge cover located at the bottom of the display-assembly hinge cover.
7. Slide the flex cable under the plastic strain relief retainer located on the bottom of the display-assembly hinge cover.
8. Reinstall the 4-mm screw that secures the metal cable clip to the left hinge of the display-assembly top cover.



## Replacing the 14.1-Inch LCD Panel

*NOTE: Use a magnetic screwdriver to reassemble the LCD panel in the display. Secure the right side first.*

1. Place the bottom edge of the LCD panel in the bottom of the top cover and elevate the top of the panel with your hand.
2. Carefully connect the LCD flex cable to the connector on the left edge of the LCD panel.

Do not force the LCD flex cable into the connector. If you have trouble, check to make sure the LCD flex cable is aligned correctly and try again.

3. Lay the LCD panel in the top cover.
4. Reinstall the six 3-mm screws securing the LCD panel to the top cover.

## 12.1-Inch Display Assembly Bezel and LCD Panel

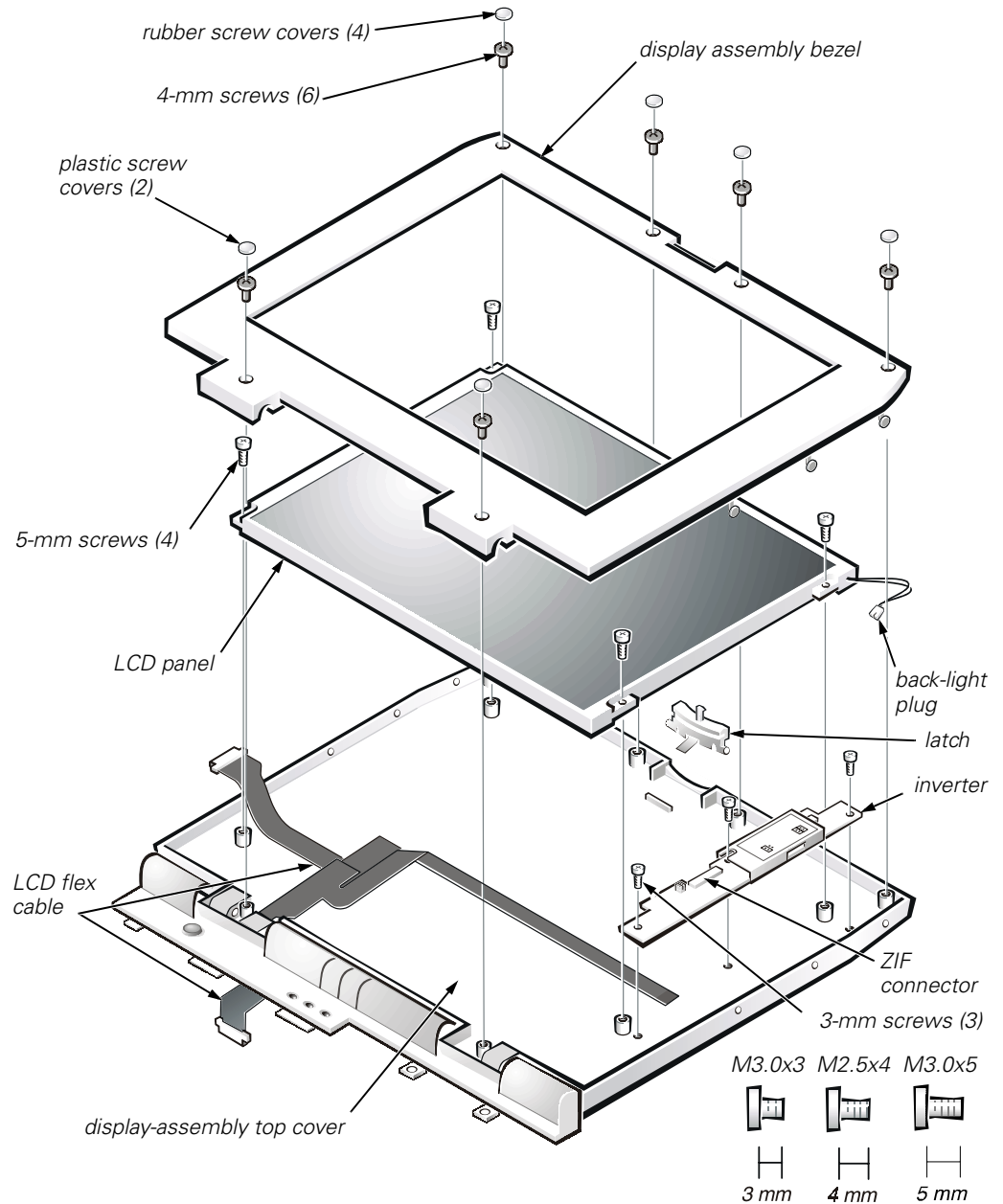

**Figure 16. 12.1-Inch Display Assembly**

### Removing the 12.1-Inch Display Assembly Bezel

1. Remove the four 5-mm screws securing the LCD panel to the top cover.
2. Disconnect the two-wire back-light plug from the connector on the inverter.
3. Lift the LCD panel and carefully disconnect the flex cable from the connector on the left edge of the LCD panel.
4. Remove the LCD panel from the top cover.



### *Removing the 12.1-Inch LCD Panel Inverter*

1. Disconnect the LCD flex cable from the ZIF connector on the inverter.
2. Remove the three 3-mm screws securing the inverter to the top cover.
3. Remove the inverter from the top cover.

### *Removing the 12.1-Inch LCD Flex Cable*

1. Remove the 4-mm screw securing the metal cable clip to the left hinge of the display-assembly top cover.
2. Remove the cable out from under the plastic strain relief retainer located on the bottom of the display-assembly hinge cover.
3. Remove the flex-cable clip from the bottom of the hinge cover located at the bottom of the display assembly.
4. Pry the hinge-cover assembly apart from the display assembly, allowing just enough space for the flex cable to pass through the opening.
5. Slide the cable through the opening.

### *Replacing the 12.1-Inch LCD Flex Cable*

1. Pry the hinge-cover assembly apart from the display assembly, allowing just enough space for the flex cable to pass through the opening.
2. Slide the cable through the opening.
3. Attach the flex-cable clip to the bottom of the hinge cover located at the bottom of the display assembly.
4. Slide the flex cable under the plastic strain relief retainer located on the bottom of the display-assembly hinge cover.
5. Reinstall the 4-mm screw that secures the metal cable clip to the left hinge of the display-assembly top cover.
6. Find the manufacturer's name on the back of the LCD panel that is to be installed.

**NOTICE: The LCD flex cable must be folded correctly before the cable connector can be attached to the connector on the LCD panel.**

7. Fold the LCD flex cable at the crease as shown in Figure 17, so that the name of the LCD panel manufacturer faces up. The manufacturer is either Torisan (T-Sanyo) or Sharp.

The connectors are identical on the Torisan and Sharp LCD panels, but they are mounted reverse with respect to each other. This means that pin 1 on the Torisan panel connector is at the opposite end when compared to pin 1 on the Sharp panel connector.

The LCD flex cable can connect to either panel by making one fold to the cable. The words *Torisan* and *Sharp* are printed on the cable (see Figure 17). If you are installing a Torisan LCD panel, fold the cable at the crease so the word *Torisan* is facing up. If you are installing a Sharp LCD panel, fold the cable at the crease so the word *Sharp* is facing up.

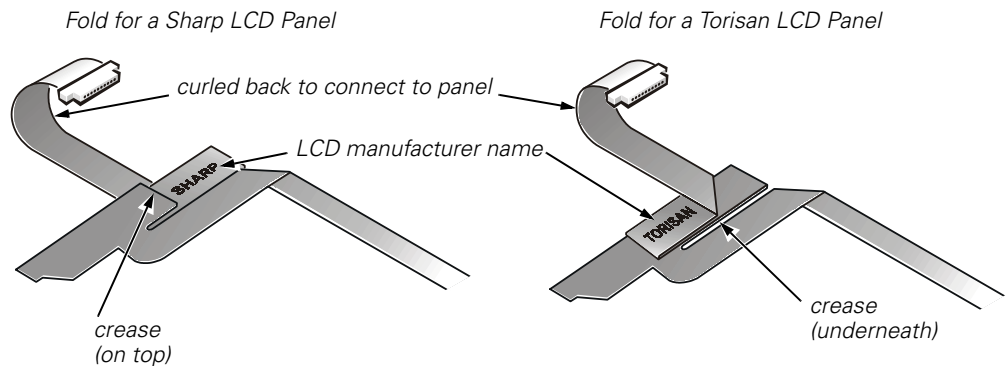

**Figure 17. 12.1-Inch LCD Flex Cable**

### Replacing the 12.1-Inch LCD Panel Inverter

To replace the 12.1-inch display LCD panel inverter, perform the following steps:

1. Find the manufacturer's name on the back of the LCD panel that is to be installed.

**NOTICE: The inverter jumpers must be configured to match the LCD panel that is installed. Improper jumper configuration can cause damage to the LCD panel.**

2. Ensure that the inverter's configuration jumpers are set correctly (see Figure 18).

If you are installing a Sharp LCD panel, both jumpers are used. If you are installing a Torisan LCD panel, the bottom jumper is used. See the sticker on the inverter shield for more information.

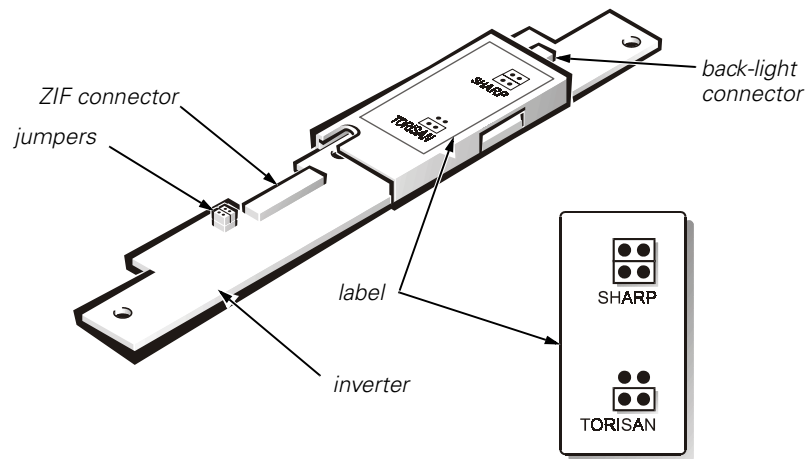

**Figure 18. 12.1-Inch LCD Inverter**

3. Place the inverter in the cover top.
4. Reinstall the three 3-mm screws that secure the inverter to the top cover.
5. Connect the LCD flex cable to the ZIF connector on the inverter.

### *Replacing the 12.1-Inch LCD Panel*

1. Find the manufacturer's name on the back of the LCD panel that is to be installed. The manufacturer is either Torisan or Sharp.
2. Make sure that the LCD flex cable is folded correctly to accommodate the LCD panel being installed. For more information see "Replacing the 12.1-Inch LCD Flex Cable."
3. Verify that the inverter jumpers are set to accommodate the LCD panel being installed. For more information see "Replacing the 12.1-Inch LCD Panel Inverter."
4. Place the bottom edge of the LCD panel in the bottom of the top cover and elevate the top of the panel with your hand.

**NOTICE: The LCD flex cable must be folded correctly before the cable connector can be attached to the connector on the LCD panel (see Figure 17).**

5. Carefully connect the LCD flex cable to the connector on the left edge of the LCD panel.

The flex cable must be curled back to connect to the LCD panel (see Figure 17).

Do not force the LCD flex cable into the connector. If you have trouble, check to make sure the LCD flex cable is folded correctly and try again.

6. Lay the LCD panel in the top cover.

7. Connect the two-wire back-light plug to the connector on the inverter.

When the plug is all the way in the connector, the key slot in the center of the plug should *not* be visible. If you can see the key slot, the plug is not in the connector correctly. Pull the plug out, turn the plug over, and reinsert it into the connector.

8. Reinstall the four 5-mm screws to secure the LCD panel to the top cover.

## ***Display Assembly Latch***

**NOTICE: To avoid damaging the system board, you must remove the main battery before you service the computer.**

1. Remove the main battery and secondary battery (if present).
2. Remove the device from the modular bay (if present).
3. Remove the display assembly.
4. Remove the LCD panel.
5. Remove the display assembly bezel latch by unsnapping the latch and captive spring from the inside of the display assembly top-cover assembly (see Figure 14 and Figure 16).

## Palmrest Assembly

The palmrest assembly consists of the touch pad and the palmrest.

**NOTICE: The reserve battery provides power to the computer's time RTC and NVRAM when the computer is turned off. Removing the palmrest disconnects the reserve battery and causes the computer to lose the date and time information as well as all user-specified parameters in NVRAM. If possible, make a copy of this information before you disconnect the reserve battery.**

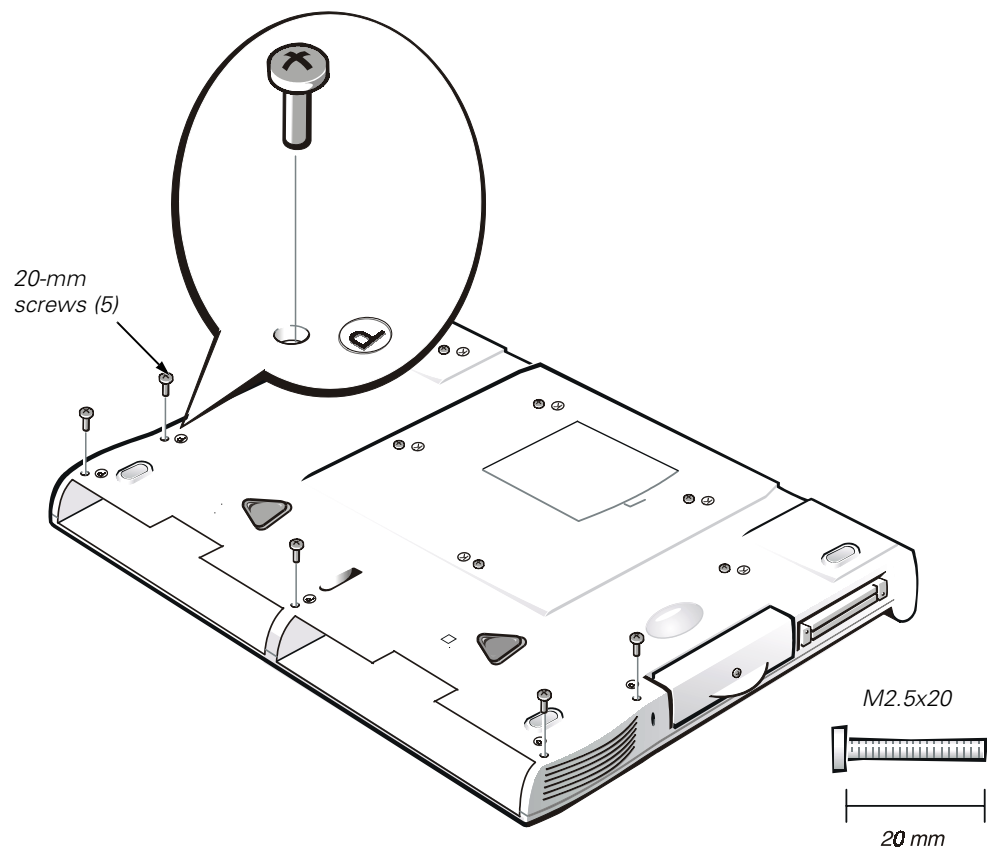

**Figure 19. Removing the Palmrest Assembly Screws**

**NOTICE: To avoid damaging the system board, you must remove the main battery before you service the computer.**

### Removing the Palmrest Assembly

1. Remove the main battery and secondary battery (if present).
2. Remove the device from the modular bay (if present).
3. Remove the keyboard.

**NOTICE: The display assembly must be removed before you can remove the palmrest.**

4. Remove the display assembly.

**NOTICE: Make sure that the work surface is clean to prevent scratching the computer cover.**

5. Turn the computer upside down on a flat work surface.
6. Remove the five 20-mm screws that secure the palmrest to the computer.  
  
These screws, labeled with a "circle P," are located underneath the front edge of the computer (see Figure 19).
7. Turn the computer right-side up on the work surface.
8. Disconnect the palmrest flex cable from the touch-pad connector on the system board (see Figure 20).

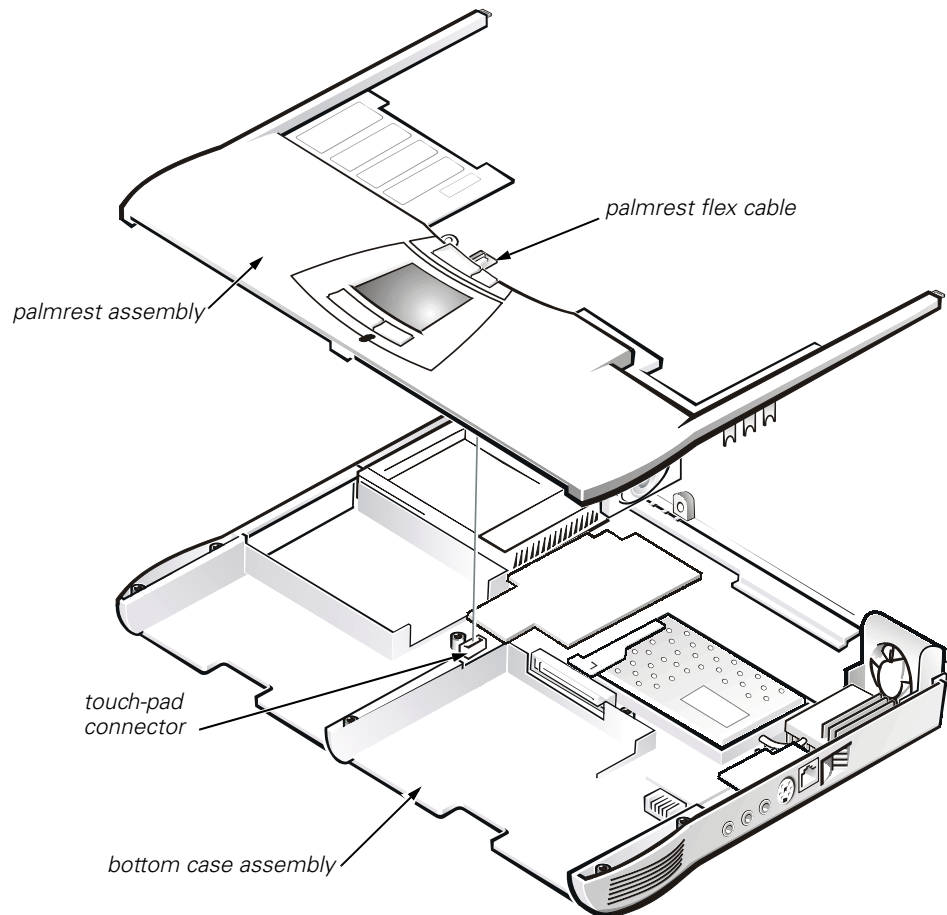

**Figure 20. Palmrest Assembly Removal**

9. Carefully remove the palmrest assembly from the bottom case assembly (see Figure 20).

## Reserve Battery

**NOTICE: The reserve battery provides power to the computer's RTC and NVRAM when the computer is turned off. Removing the battery causes the computer to lose the date and time information as well as all user-specified parameters in NVRAM. If possible, make a copy of this information before you remove the reserve battery.**

### Removing the Reserve Battery

1. Remove the main battery and secondary battery (if present).
2. Remove the device from the modular bay (if present).
3. Remove the keyboard assembly.
4. Remove the display assembly.
5. Remove the palmrest assembly.
6. Turn the palmrest assembly over.
7. Remove the two 4-mm screws securing the palmrest bracket. This may loosen the reserve battery EMI spring clip which is secured to the palmrest bracket.
8. Lift the palmrest bracket and turn it over, taking care not to twist the touchpad cable.
9. Disconnect the reserve battery cable from the connector on the palmrest bracket.
10. Remove the reserve battery from the palmrest bracket as follows:
  - a. Pry the reserve battery free from the foam pad.
  - b. Remove the remnants of the foam pad from the palmrest bracket.



*NOTES: When you replace the reserve battery, first connect the reserve battery cable to the connector on the palmrest bracket. Then position the reserve battery on the palmrest bracket to minimize slack in the cable.*

*Carefully reposition the reserve battery EMI spring clip before securing the two 4-mm palmrest bracket screws.*

## Modem Assembly

The modem assembly is optional. The modem (if present) must be removed before the main system board can be removed (see Figure 21).

**NOTICE: To avoid damaging the system board, you must remove the main battery before you service the computer.**

### Removing the Modem Assembly

1. Remove the main battery and secondary battery (if present).
2. Remove the keyboard assembly.
3. Remove the display assembly.
4. Remove the palmrest assembly.
5. Remove the 10-mm screw and washer securing the modem assembly (see Figure 21).

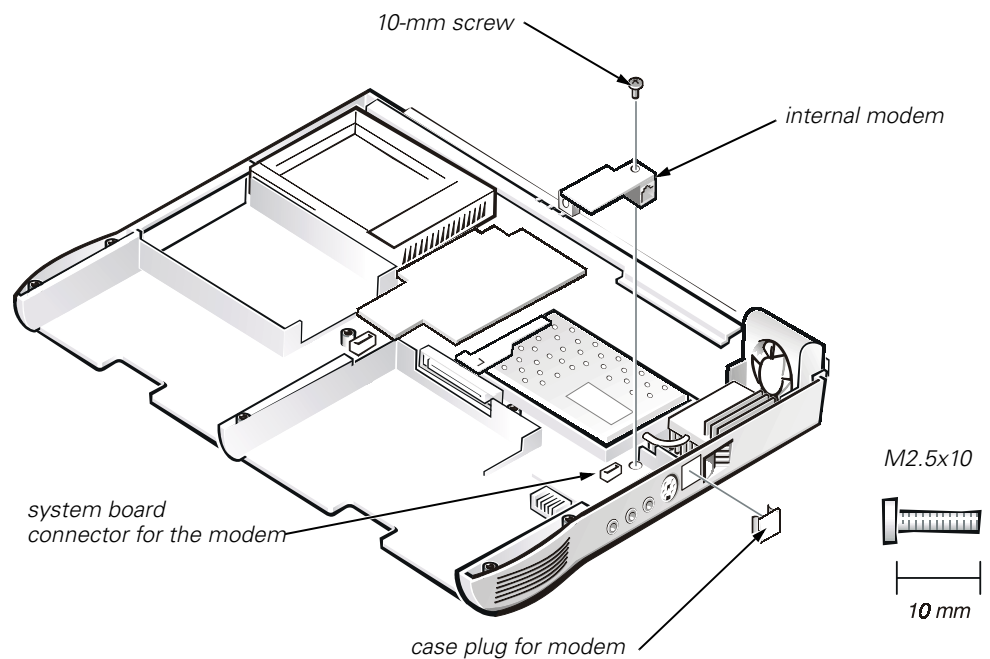

**Figure 21. Modem Assembly**

### Replacing the Modem Assembly

1. Press the RJ11 connector of the modem assembly into the hole in the bottom case assembly.
2. Carefully align and press the modem into the system board connector.
3. Replace the internal modem 10-mm screw and washer (see Figure 21).



## System Board Assembly

The system board's basic input/output system (BIOS) chip contains the system service tag number, which is also visible on a bar-code label on the bottom of the computer. The replacement kit for the system board assembly includes a diskette that provides a utility for transferring the service tag number to the replacement system board assembly.

### Removing the System Board

**NOTICE: To avoid damaging the system board, you must remove the main battery before you service the computer.**

1. Remove the main battery and secondary battery (if present).
2. Remove the device from the modular bay (if present).
3. Remove the keyboard assembly.
4. Remove the display assembly.
5. Remove the palmrest assembly.
6. Remove the microprocessor module.
7. Verify that all PC Cards or plastic blanks are removed from the PC Card slot.
8. Verify that the PC Card ejectors do not extend from the PC Card slot.
9. Remove the two screws securing the system board assembly (see Figure 22).
  - Locate and remove the 4-mm screw with captive washer on the far left side of the computer between the hard-disk drive assembly and the PC Card slot.
  - Locate and remove the 4-mm screw with captive washer on the far right side of the computer in front of the thermal cooling assembly and to the right of the microprocessor module. This assumes that an optional modem is not present.



*NOTES: If the optional modem is present in your system, locate and remove the 10-mm screw with washer that secures the modem assembly.*

*You can easily locate these screws by looking for the white marks on the system board (or modem) that outline the captive washers (see Figure 22).*

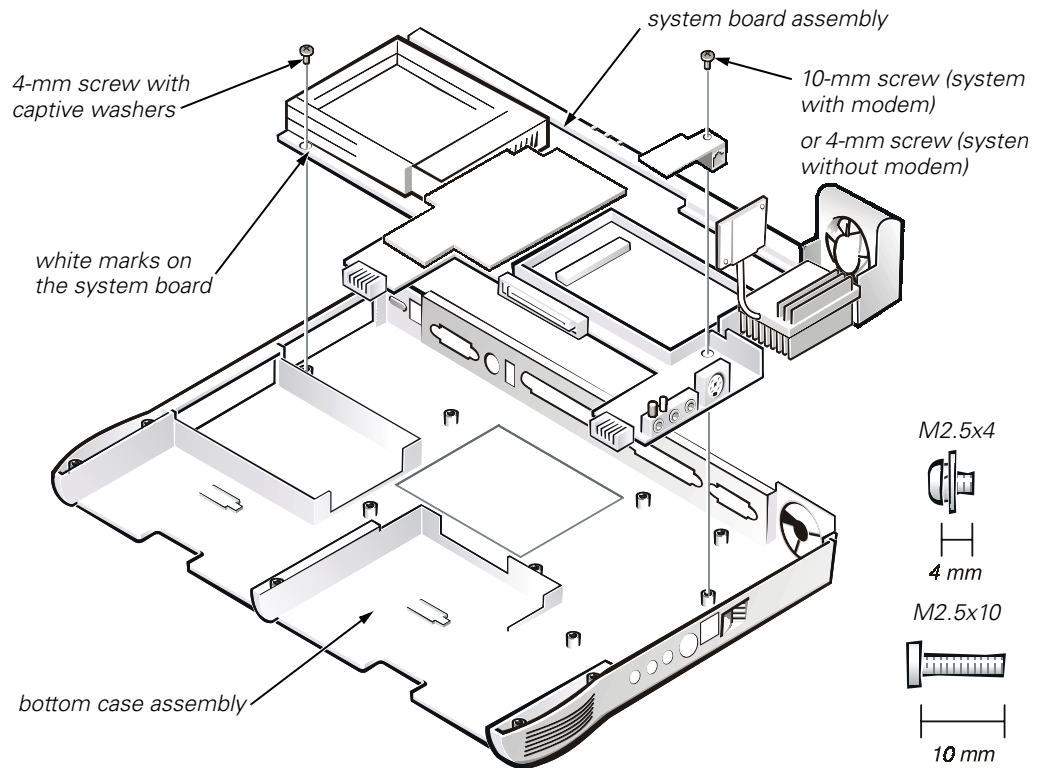

**Figure 22. System Board Assembly**

10. Remove the modem (if present).
11. Lift the system board assembly out of the bottom case assembly.

### Replacing the System Board

1. Install the replacement system board.
2. Replace the modem (if present).
3. Replace the system board mounting screws.
4. Replace the microprocessor, the palmrest assembly, the display assembly and the keyboard assembly.



*NOTE: Be sure to transfer the memory module(s) to the replacement system board assembly.*

5. Replace the modular bay devices and any PC Cards or plastic blanks in the PC Card slot.
6. Insert the diskette (or CD-ROM) that accompanied the replacement system board assembly into the appropriate drive, and turn on the computer. Follow the instructions on the display screen.



*NOTE: After replacing the system board assembly, be sure to enter the system's service tag number into the BIOS of the replacement system board assembly.*

## Thermal Cooling Assembly

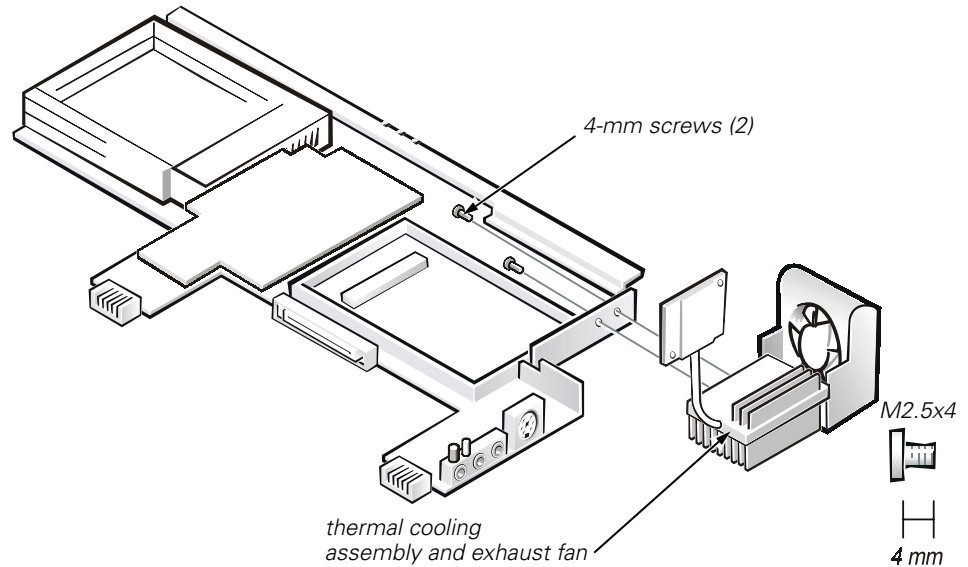
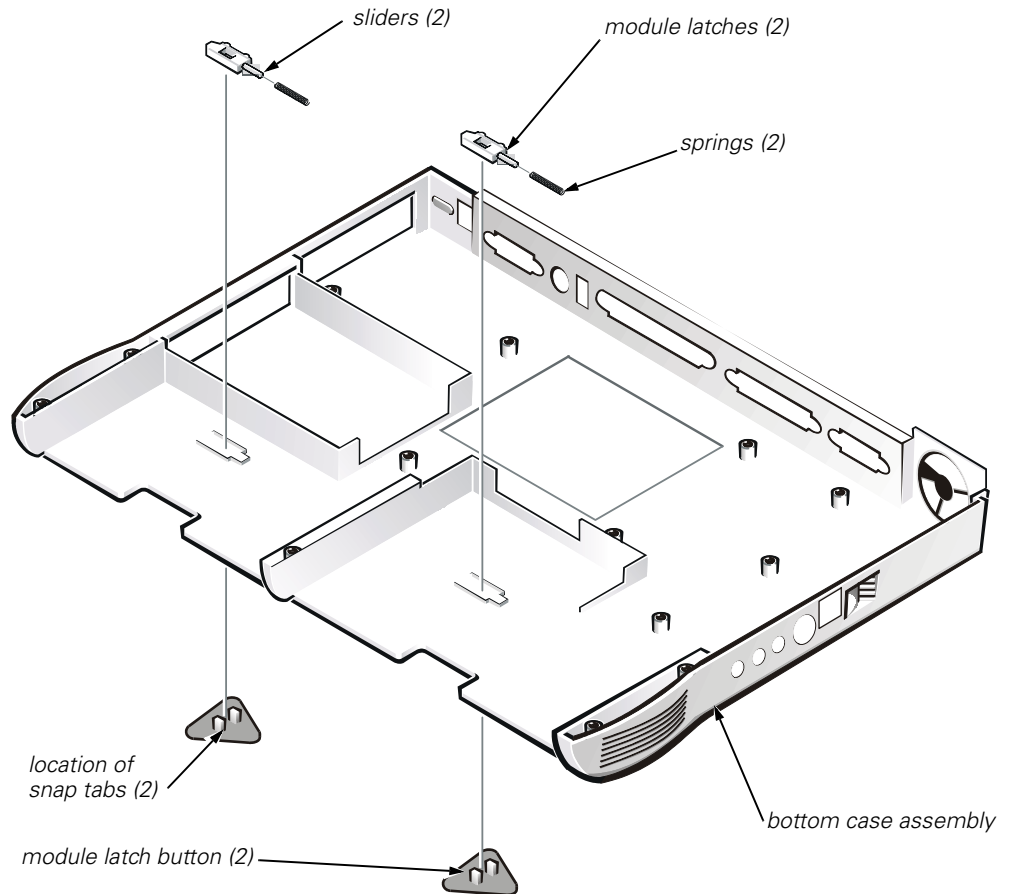

**Figure 23. Thermal Cooling Assembly Removal**

**NOTICE:** To avoid damaging the system board, you must remove the main battery before you service the computer.

1. Remove the main battery and secondary battery (if present).
2. Remove the device from the modular bay.
3. Remove the keyboard assembly.
4. Remove the display assembly.
5. Remove the palmrest assembly.
6. Remove the microprocessor module.
7. Remove the modem (if present).
8. Remove the system board assembly.
9. Disconnect the exhaust-fan power cable from the connector on the system board.
10. Remove the two 4-mm screws securing the thermal cooling assembly and exhaust fan, and then remove the thermal cooling assembly and exhaust fan (see Figure 23).

## Module Latch Assemblies



**Figure 24. Module Latch Assemblies Removal**

**NOTICE: To avoid damaging the system board, you must remove the main battery before you service the computer.**

1. Remove the main battery and secondary battery (if present).
2. Remove the device from the modular bay.
3. Remove the keyboard assembly.
4. Remove the display assembly.
5. Remove the palmrest assembly.

6. Remove the left module latch button from the bottom case assembly by carefully squeezing the snap tabs (see Figure 25).

Apply pressure to the module latch and spring while unsnapping the snap tabs to prevent the module latch assembly from coming loose from the case. If the module latch assembly does come loose from the case:

- a. Carefully reinsert the spring onto the slider on the module latch, and reinstall the module latch into the holding features on the inside of the case.
  - b. Ensure that the slider is inserted in its respective hole, that the side of the latch with the two bumps is facing the back of the case, and that the surface with the wear ribs is facing the bottom of the case (see Figure 25).
7. Snap in the new latch button from the bottom of the base, making certain its snap tabs are fully engaged in the module latch.
  8. Ensure that the newly installed latch moves smoothly and freely when pushed and released.
  9. Repeat steps 6 through 8 for the latch on the right side.

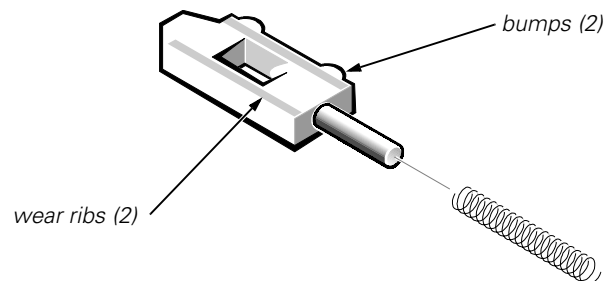

**Figure 25. Left Module Latch and Spring**



# Index

## Numbers

- 12.1-inch LCD display panel
  - removal, 25
  - replacement, 28
- 12.1-inch LCD flex cable
  - removal, 26
  - replacement, 26
- 12.1-inch LCD panel inverter
  - removal, 26
  - replacement, 27
- 14.1-inch LCD display panel
  - removal, 22
- 14.1-inch LCD flex cable
  - removal, 22

## B

- battery (in modular bay)
  - removal, 12
- battery (reserve)
  - removal, 32

## C

- CD-ROM drive
  - removal, 12
- computer
  - exploded view, 10
  - working inside, 2

## D

- diskette drive
  - removal, 12
- display assembly
  - bezel, removal, 21
  - removal, 20
- display assembly latch
  - removal, 29
- display panel, 12.1-inch LCD
  - removal, 25
  - replacement, 28

## F

- field-replaceable parts and assemblies
  - illustrated, 10
  - list of, 6
- flex cable, 12.1-inch LCD
  - removal, 26
  - replacement, 26
- flex cable, 14.1-inch LCD
  - removal, 22

## G

- grounding to dissipate static electricity, 3

## **H**

hard-disk drive assembly  
removal, 11

## **I**

inverter, 12.1-inch LCD panel  
removal, 26  
replacement, 27

## **K**

keyboard assembly  
removal, 15

## **M**

memory module  
removal, 13

memory module cover  
removal, 12

microprocessor module  
removal, 18

modular bay devices  
removal, 12

module latch assemblies  
removal, 37

## **P**

palmrest assembly  
removal, 30

## **R**

reserve battery  
removal, 32

## **S**

screw identification and tightening, 3

sockets  
memory module, 13

SuperDisk LS-120 drive  
removal, 12

system board assembly  
removal, 18

## **T**

thermal cooling assembly  
removal, 36

tools, 2

travel module  
removal, 12

## **Z**

ZIF connectors, 5



Printed in the U.S.A.

**DELL**™



\* 6 4 P T N \*

P/N 64PTN Rev. A00

[www.dell.com](http://www.dell.com)